

Quick Installation Guide (TLSeries)

Thank you for using our products.
This guide provides only easy installation steps.
Please refer to this product manual for specific requirements.

Web: www.inverter.com
Tel: +1 800-585-1519
Email: sales@inverter.com

1 Items In The Package



Product



Wall-mounted bracket



User manual and related after-sales service guarantee materials
Accessory pack 1



The specific quantity of accessories is configured according to the corresponding mode
Accessory pack 2



Functional unit (optional)

2 System Connection Diagram

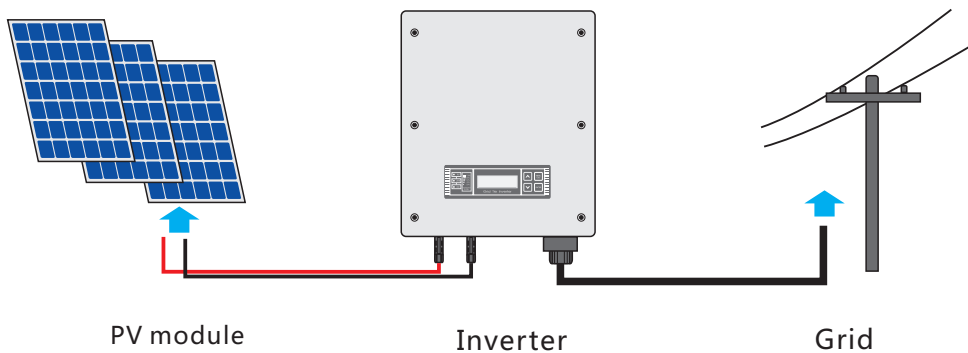

3 Wiring Diagram Description

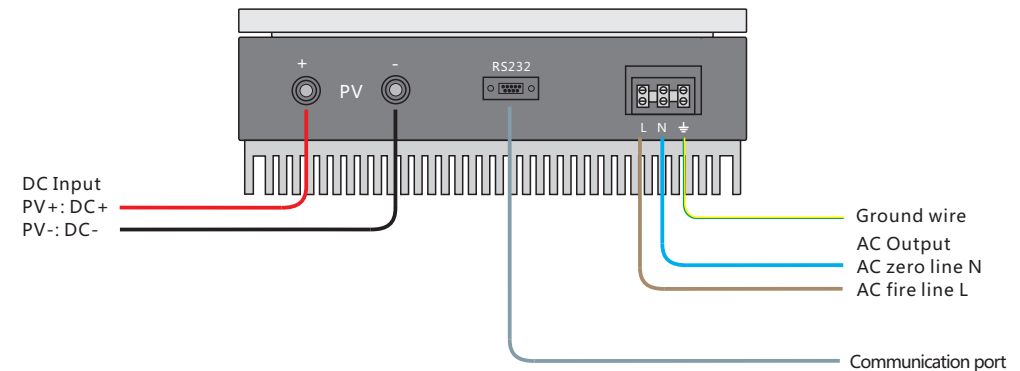

4 Install Inverter

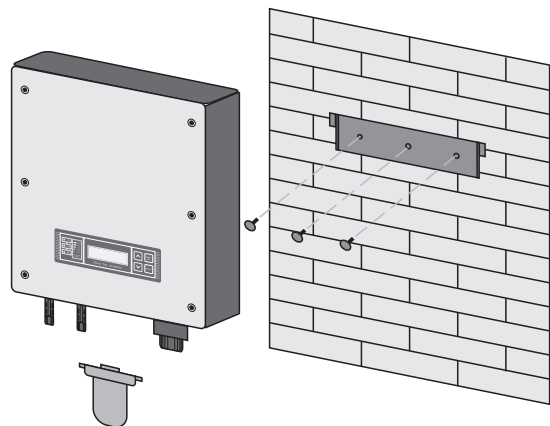

1. Choose an installation position, the wall must be firm and reliable.
2. Remove the bracket of the product.
3. Fix the bracket with the expansion screws in the package.
4. Place the product on the bracket and fix it with screws.

6 AC Terminal Making And Wiring

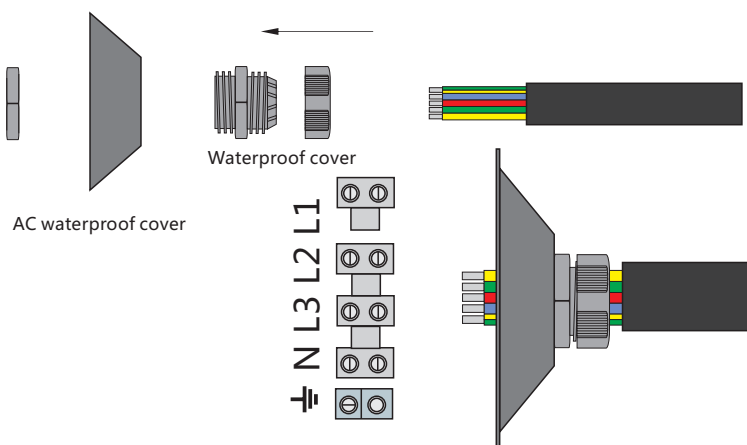

1. Remove the AC waterproof cover from the product
2. Find PG16 waterproof connector in the accessories, install the connector to the waterproof cover.
3. Select the correct tool, peel off the wire sheath (10mm).
4. Connect the wire correctly to the AC terminal according to the wiring diagram.
5. Fix the waterproof cover to the product, tighten PG16 waterproof head and cover.

5 DC Terminal Making And Wiring

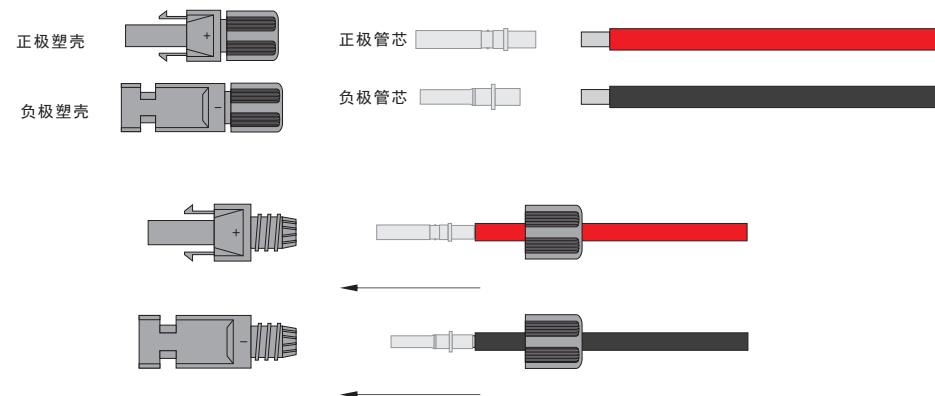

1. Find the DC terminal in the accessory package.
2. Select the correct tool, peel off the wire sheath (8mm), press the terminal metal tube core, note the positive and negative can not be reversed.
3. Put the tube core into the corresponding plastic case and tighten it. Before that, the wire should go through the waterproof cover of the plastic case at the same time.
4. Tighten the waterproof cover, connect the positive and negative terminals to the product.

7 Operation Panel Introduction And Initial Grid Connection

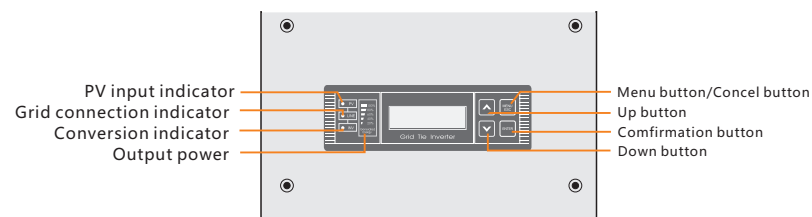

After the previous steps of wiring, can try to start up and connect to the grid for the first time..

1. First, turn on the DC input switch, the input indicator light up, the LCD light up, confirm whether the DC display of the input voltage is normal (as shown on the right picture 1).
2. Then turn on the AC grid switch, the grid indicator light up and flashing, the LCD will display the current grid voltage and frequency, the countdown starts in the upper right corner of the screen (as shown on the right picture 2).
3. While the countdown is over, the inverter will automatically start the conversion. The conversion indicator light up, the word in the upper left corner of the screen changes from STOP to RUN, the letters in the upper right corner change to RD, the power and current values start to rise (as shown on the picture below), which means the grid connection is successful (as shown on the right picture 3).
4. If the grid connection failed, please refer to the troubleshooting section in the user manual. After the countdown of grid connection, it shows "D: Reverse phase set?" It means the line sequence is wrong, please turn off the power, exchange the AC lines L1 and L2, then reconnect to the grid.

