

WVC-300 micro inverter

WiFi/433MHz Version **User manual**



WVC300-433/WiFi Micro inverter



Parameter

Model	WVC350-R3-433/WiFi	
Maximum input power	360Watt	
Output voltage mode	120/230V Auto switch	
PV Open circuit voltage	30-60VOC	
Operating voltage range	22-60V	
Starting voltage range	22-60V	
short-circuit current	14A	
Maximum working current	11.5A	
Output parameters	@120V	@230V
Output peak power	360Watt	360Watt
Rated output power	300Watt	300Watt
Output current	2.5A	1.3A
AC voltage range	80-160VAC	180-280VAC
AC frequency range	48-51Hz/58-61Hz	48-51Hz/58-61Hz
Power factor	>95%	>95%
Number of branch connections.	15PCS (Single)	30PCS (Single)
Output efficiency	@120V	@230V
Static MPPT efficiency	99.5%	99.5%
Max output efficiency	95%	95%
Loss of power at night	<0.5W	<0.5W
Total current harmonics	<5%	<5%
Appearance and technical features		
Temperature range	-40°C to +65°C	
Size (L×W×H)	165mm×176mm×38mm	
Net amount	0.8kg	
Waterproof grade	Ip65 NEMA3R	
Heat dissipation mode	Self-cooling	
Communication mode	433MHz/WiFi	
Power transmission mode	Reverse transmission, Load priority	
monitoring system	Mobile phone APP、 Browser	
electromagnetic compatibility	EN50081.part1 EN50082.Part1. CSA STD.C22.2 No.107.1	
Power grid	EN61000-3-2 EN62109.UL STD.1741	
Power grid detection	DIN VDE 0126 IEEE STD.1547.1547.1 and 1547.A	
certificate	CEC , CE , INMETOR , ETL , Patented technology	
Packing weight		
Specifications	Each (Packing)	Box (15PCS)
weight	1 KG	15.96 KG
Size	245×202×60mm	450×395×345mm

Features

- Maximum power point tracking
- Adaptive voltage/frequency
- App monitoring system
- Reverse power transmission
- Internal high precision meter
- Forward full-bridge topology
- I / O, fully isolated
- Voltage mode microgrid
- No installation, no maintenance
- Multiple parallel stacks
- 5G lot Platform management

System

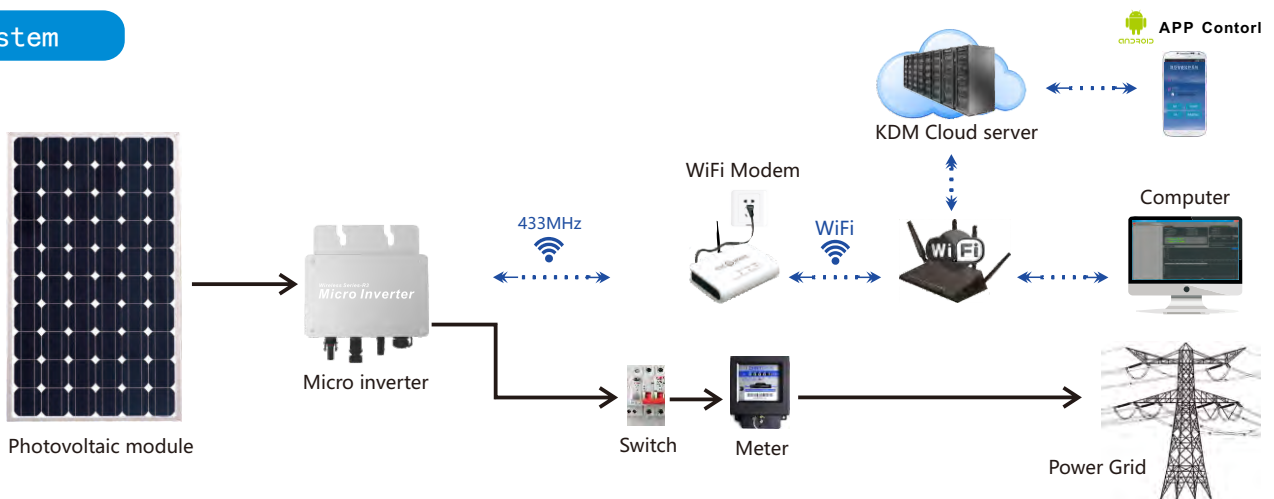

Appearance description of micro inverter

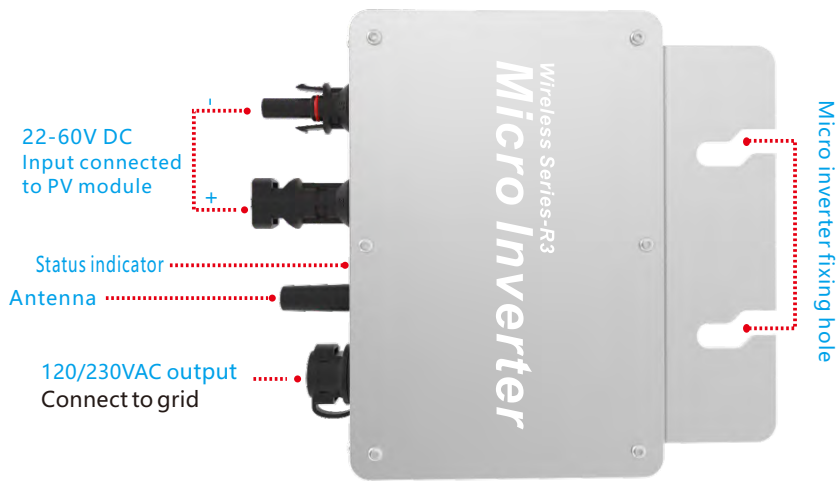

Instructions



Screw Kit



AC Plug



Handshake connecting cable
You need to buy it separately.

Accessories of micro inverter



Note: You can purchase a professionally customized AC bus with a T-type connector. Use this AC bus as the AC bus for each branch. Connect it hand in hand to form a modular micro-inverter branch wiring system.

Description of the connector and cable core of the micro inverter

2-L-Live wire 1-N-Neutral

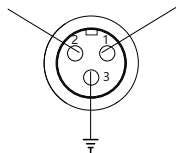

3-G-Ground

Wire end connector

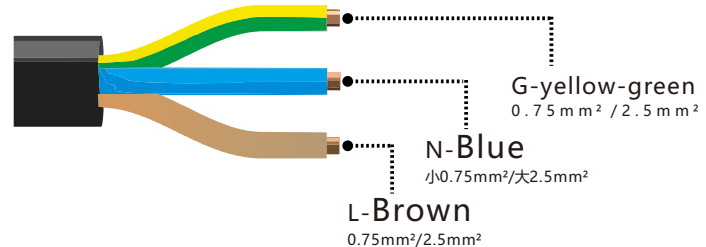

LED indicator function of micro inverter

- 1.Red light is on---The micro-inverter is powered on, the red light is on, and the equipment is ready to work;
- 2.Red light flashes----The micro-inverter is fully prepared and enters the delayed startup state;
- 3.Flashing green-----MPPTMaximum power point search status;
- 4.Green light is on----MPPTMaximum power point locked state;
- 5.The green light turns red----a.Island protection; b. Frequency protection; c. AC over/under-voltage protection; d. DC voltage over and under voltage protection; e. fault; f. software shutdown;

Normal working indicator flashing process:

Connect the micro-inverter to the AC and DC terminals, and then turn on the power → the red light will be on for 3 seconds → the red light will flash for 30 seconds → the green light will flash quickly (MPPT maximum power point search) → The green light is on, (MPPT lock).

433MHz Long distance communication

The communication method of 433MHz is a short connection method, that is, the signal is disconnected after sending / receiving. The device for data collection with the inverter is WiFi-MODEM. The communication channel is civilian channel. Long-distance wireless transmission (open area up to 1800 meters, good wall penetration capability, air baud rate 500bps) Operating frequency range (433.4-473.0MHz, up to 100 communication channels) Maximum 100mW (20dBm) transmit power 8 levels of power can be set) Four working modes, suitable for different applications, please refer to the WiFi-MODEM instruction manual for specific usage details.



Power monitoring system diagram

Data collection: power, voltage, current, temperature
Data analysis: power and electricity year, month, day, analysis
Function control: remote control of power on / off and power adjustment
Data storage: Cloud platform data storage data will never be lost
Fault alarm: monitor the operation of the equipment throughout the process, at a glance

WiFiData collector usage settings

1、Preparation for use :

If you want to use the monitoring system of WVC series micro-inverters, you must install and set up WVC series WiFi data collector. WiFi data collector is the data exchange bridge of WVC series micro-inverters. It is in the micro-inverter, The function of data collection and data exchange between computers, using 433MHz signal to send the voltage, current, temperature, power and other data of the micro-inverter to the KDM server via WiFi signal, computer can smoothly monitor the power generation data of the power station , Please connect the antenna and power cable of the data collector as shown on the right.

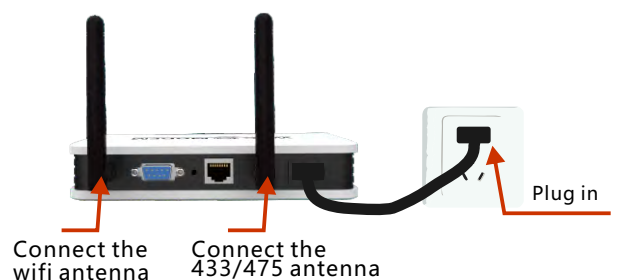

WiFi Modem hardware connection diagram

2、Immediately monitor your power plant and keep track of your power plant data :

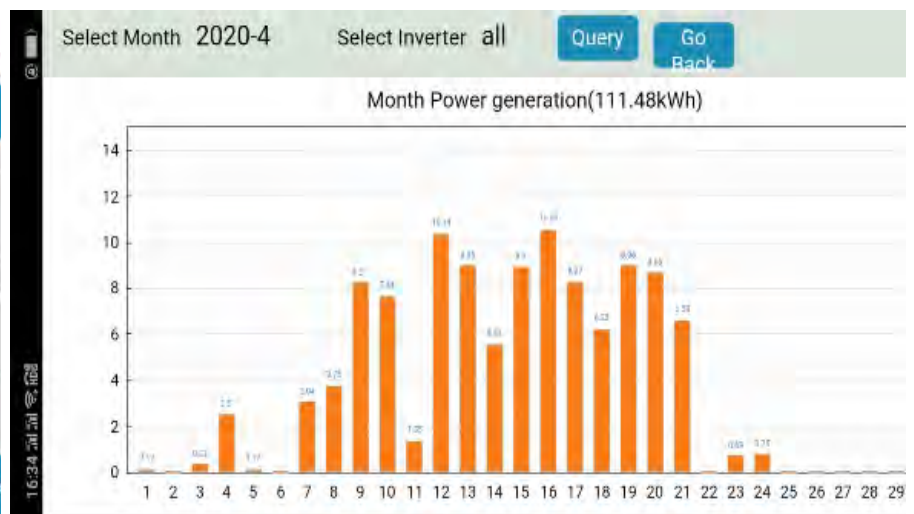
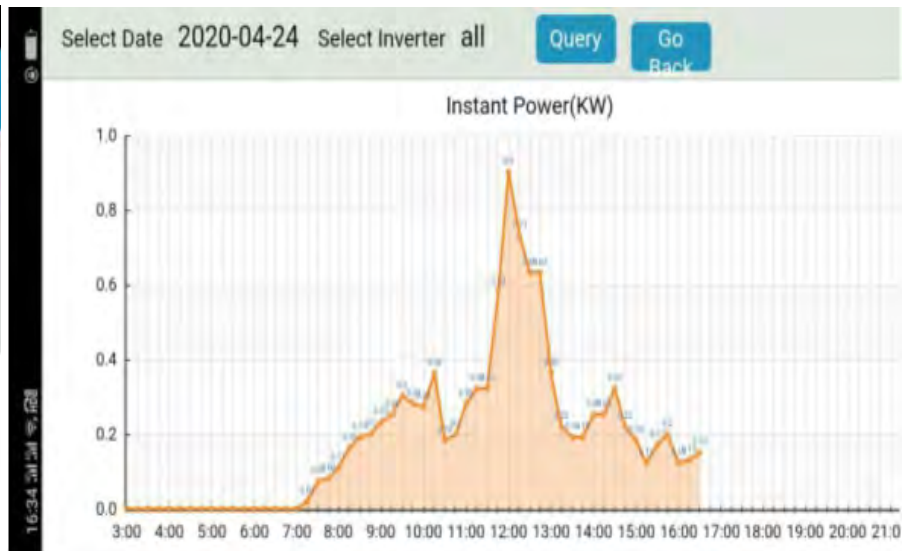
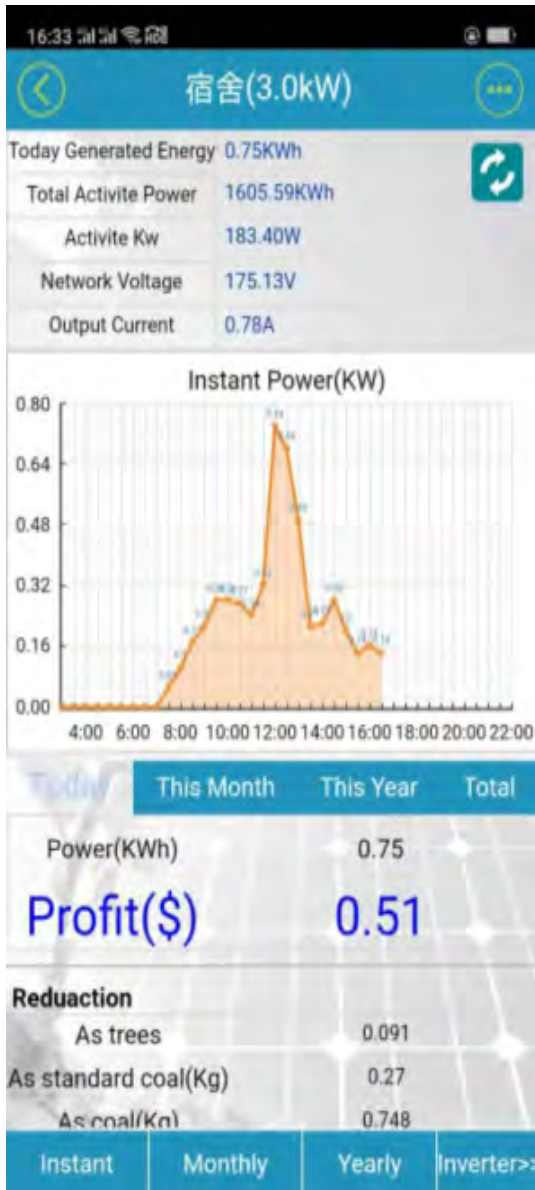

WVC series micro-inverter installation guide

To properly install and use WVC series micro inverters, please read and follow this guide and all warnings and instructions in WVC micro inverters. The "Installation and Operation Manual" can be downloaded from the official website of inverter Energy: www.inverter.com. Safety warnings are listed on the back of this guide. All models of WVC Series Micro inverter listed in this guide have a ground wire in the AC cable, no additional ground electrode is required (EGC), there are three wires inside the AC cable with equipment, which are Blown zero line N (Blue) ground wire / safety line G (Yellow & green). Each micro-inverter is equipped with an AC cable with a length of 3 * 4 * 2 meters. The current of each AC cable branch cannot be greater than 40A. For the number of connected branches of each branch, refer to the following installation guide.

Important information: WVC series micro-inverters use IP65 waterproof rating. When installing, please try to install it in a place where there is no rain, nor in a place where the sun is exposed to ensure ventilation and heat dissipation.

Preparation before installation:

- Please visit our company's official website www.inverter.com, then open the website and register an account on it, and create a power station on the account to reverse the WVC series. The inverter is monitored or controlled. For detailed operation, please refer to the instructions in the inverter monitoring section.
- The device for data collection with the inverter communication is WiFi-MODEM, and the communication method between WiFi-MODEM and inverter is long-distance wireless transmission (open field 1800 meters, air baud rate 00bps). Operating frequency range (433.4-473.0MHz Up to 100 communication channels) Maximum 100mW (20dBm) transmit power (8 levels of power can be set) Four working modes, suitable for different applications, please refer to the WiFi-MODEM manual for details.
- Please refer to the following list and compare the electrical parameters of the solar modules in the table to select the inverter model.

Inverter model	Connector	Photovoltaic module
WVC-295	1*MC4	The number of matched photovoltaic modules is 60 strings / 72 strings / 90 strings. The open circuit voltage Voc is between 30-60V
WVC-300	1*MC4	
WVC-350	1*MC4	
WVC-600	2*MC4	
WVC-700	2*MC4	
WVC-1200	4*MC4	
WVC-1400	4*MC4	
WVC-2000	4*MC4	
WVC-2400	4*MC4	
WVC-2800	4*MC4	

- In addition to WVC series micro-inverters, you must also purchase photovoltaic brackets / AC boxes / electrical cables and other related materials. The current of each channel of the WVC series micro-inverters at the branch of the installed circuit cannot exceed 40 Amp, if the rated current is exceeded, it may lead to an unsafe factor.
- Check if you still have the following related equipment: AC junction box, tools: screwdriver, wire cutter, voltmeter, torque wrench, socket and wrench for installing hardware, etc.

- After the installation of the power station is completed, please install a ground wire on the photovoltaic support, install and use a lightning protection and / or surge suppression equipment protection system in the AC junction box. It is very important to have a switch device that automatically protects against lightning strikes and surges.
- When installing the inverter handshake cable, please plan that your AC branch circuit cannot exceed the current limit, so that the maximum number of micro-inverters in each branch can be reasonably allocated.

Inverter model	Number of branches
WVC-295	30PCS
WVC-300	30PCS
WVC-350	25PCS
WVC-600	15PCS
WVC-700	12PCS
WVC-1200	8PCS
WVC-1400	6PCS
WVC-2000	5PCS
WVC-2400	4PCS
WVC-2800	4PCS

*Each region may be different. Please refer to local requirements to define the number of micro-inverters per branch in your area.

- Implement all national electrical codes (NEC), ANSI / NFPA 70 in accordance with all local electrical codes and all relevant regulations.
- Please note that only qualified personnel can install and / or replace micro-inverters.
- Please do not try to repair micro-inverter. It does not contain user-serviceable parts. If it fails, please contact customer service to obtain the ID number and start the replacement process. Tampering or opening the micro inverter will invalidate the warranty.
- Before installing or using Micro Inverter, please read all instructions and technical instructions and the warning mark system and photovoltaic array on Microinverter.
- Please make sure that the installation operation is performed before the AC power is disconnected, and do not install the micro-inverter with power on.
- Please install micro inverter series products as shown in the following figure.

WVC-300 micro inverter installation drawing

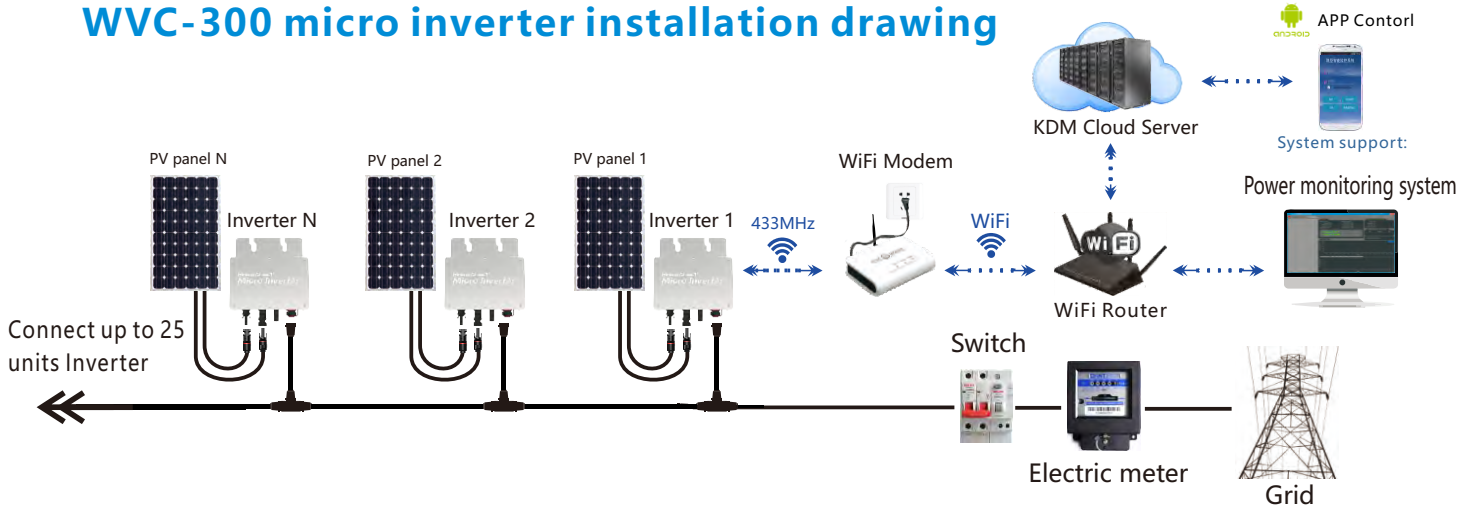

Inverter installation steps

Step 1 Install the inverter on the bracket of the photovoltaic panel with the screws provided with the machine, as shown in the following figure:

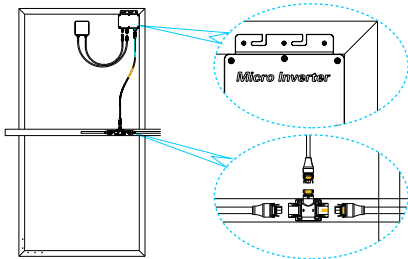

Step 2 Connect the positive and negative poles of the DC connection MC4 plug on the photovoltaic board to the DC input terminal of the inverter, as shown below:

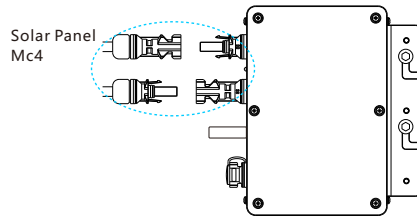

Step 3 Open the waterproof cover of the AC output connector of the inverter and connect the AC cable to the AC waterproof plug. The connection method is as shown in the plug connection diagram:

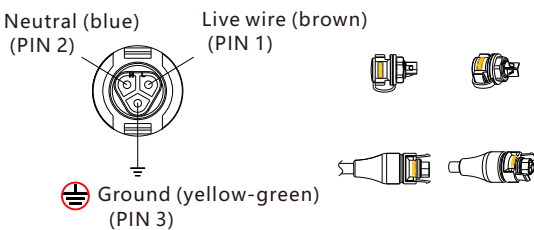
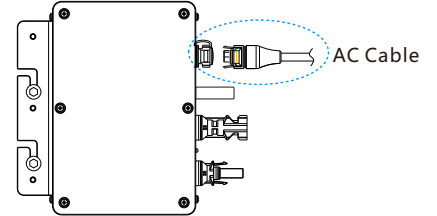

Step 4 Connect the AC output cable to the AC main cable;
Step 5 Repeat steps 1 to 3, install and connect all inverters;
Step 6 Connect the AC main cable to the utility grid to start your green energy journey.

Note: Before installing WVC series micro inverter products, please read this manual and pay attention to the installation details. This manual contains important instructions that should be followed when installing and maintaining. Reduce the risk of electric shock and ensure safe installation and operation of MicroInverters. Always follow the following safety symbols present in this document to indicate hazardous conditions and important safety Instructions.

Wiring Diagram WVC-300 Triple Phase

